

Model 9502 16-Channel SC Duplex Multimode Fiber to RJ45 RS485/422 Media Converter

- **Ideal for Casino Networks linking Video Lottery Terminals & Video Gaming Machines.**

INTRODUCTION:

The **Model 9502** is a high speed ruggedized 16-Channel SC Duplex Multimode Fiber to RJ45 RS485/422 media converter. Typical operating speeds are up to 5 Mbps for RS485/422 to fiber conversion. When operating in RS485/422 mode, each converter can be configured for 2-wire half duplex or 4-wire full duplex operation. Each converter can be configured as a DCE or DTE interface.

Default: Each converter is configured as a DCE interface with 4-wire full duplex operation.

Applications: The converters provide an industrial solution for applications requiring a single point-to-point over short and long distances. Applications include: Casino Networks linking Video Lottery Terminals, PC to PC long distance communications, factory automation, barcode readers, time clocks, scales, data entry terminals, ATM's and serial communications in harsh environments.

FEATURES:

- The power input has reverse polarity protection; it is also protected from transients, over current and over voltage.
- All copper RS485/422 ports are 8-pin RJ45 connectors.
- ESD and high-power transient protection on copper interfaces.
- All fiber optic ports are SC Multimode connectors. The ports accept Multimode fiber size is 62.5/125 μm or 50/125 μm , and wavelength 820 nm/850 nm multimode.
- All fiber ports are standard fiber optic transceivers that receive and drive the fiber optic signal, where the RX is on the left and the TX is on the right.
- Other features include user selectable fiber polarity, TX (Green) and RX (Yellow) LED Indicators.
- Each RJ45 Interface Connector has 1 (Green) LED for a fiber TX indicator and 1 (Yellow) LED for a fiber RX indicator.



Specifications:

Fiber Interface:

(32) Connectors: Fiber Optic Multimode SC Duplex
(16) TX and (16) RX.
TX Power: -12.5 dBm
RX Sensitivity: -27.5 dBm
Optical Budget: 15 dB
Max. Link Distance with 62.5/125 μm fiber:
5.35 km at up to 5 Mbps, 25°C
3.75 km at up to 5 Mbps, -40°C to +85°C
Wavelength: 820 nm/850 nm, multimode
Fiber Size: 50/125 μm , 62.5/125 μm , 100/140 μm

Fiber Polarity:

Logical 1 = Light ON/OFF: Jumper Selectable

Copper Interface:

(16) Connectors: RJ45, Female
Type: RS485/422 (2-wire/4-wire)
Terminations: RS485/422 120 Ohm jumper selectable

Bit Rate (nom.):

RS485/422 0 to 5 Mbps

Network Configurations:

RS485/422 Point-to-Point

Indicators:

LEDs: (16) TXD and (16) RXD.

Power:

Input Power: 5VDC@2A

Operating Environment:

-40°C to +85°C

Power Supply:

Model 9502 is supplied with an external 5VDC, 4A power supply operating from 90-240VAC@50/60Hz. The power supply is UL listed and LPS approved. The unit also comes with a 2-prong US non-polarized NEMA 1-15P plug. The power supply is P/N 522586.

Model 9502 Mechanical (Desktop Unit):

Model 9502 Cat No: 309502

Size: 19.0" x 3.50" x 8.11" [48.3 x 8.9 x 20.6 cm]

Weight: 5.7 lbs [2.6 kg]

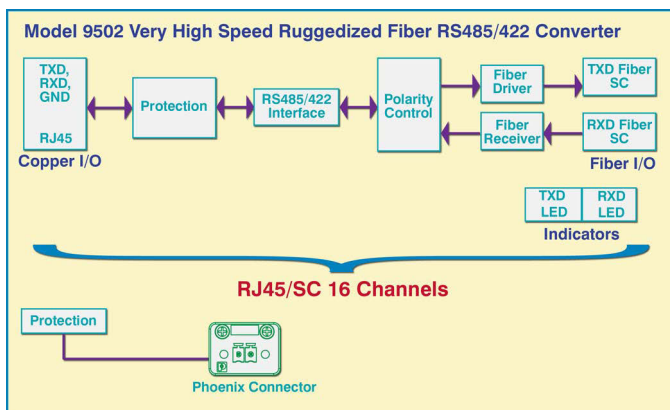

Model 9502 16-Channel SC Duplex Multimode Fiber to RJ45 RS485/422 Media Converter

