

PathWay® Model 7352 Dual Channel Cat5e RJ45 A/B/OFFLINE Switch with 10/100 BASE-T Remote Access and GUI

IP Addressable! Communicate with Switch via Internet Explorer running a PC.

INTRODUCTION

The PathWay® Model 7352 Dual-Channel RJ45 Cat5e A/B/OFFLINE Switch with Telnet and GUI allows the user the capability of sharing a single port interface device, connected to the "COMMON" port, among two other devices, connected to the "A" and "B" ports, for each channel. Remote Control access can be accomplished using an Ethernet 10/100BASE-T connection and either Telnet Commands or Graphical User Interface. The Model 7352 is enclosed in a 1U, full rack size, all metal black chassis designed to provide EMI/RFI shielding and fit in a standard 19" rack.

FEATURES:

- Each channel allows access to two Cat5e RJ45 networks from one COMMON network or device.
- The switch ports are transparent to all data.
- All (8) pins of the RJ45 interface are switched via break-before-make electromechanical relays.
- Independent control of each channel with Gang Controls.
- **No local control.**
- **Switch reverts to the "Offline" position on power loss and isolates all ports.**
- **Switch remains in the "Offline" position on power up.**
- Control of the switch position from a 10/100Base-T LAN Ethernet environment.
- Remote Telnet Command Interface or Graphical User Interface that allows the user to control switch position, obtain switch status, as well as, query firmware version number, query serial number.
- Remote control of the switch is password protected, where the password protection can be disabled.
- Front panel LED's display present position and power status.
- **Certified for Cat5e compliance.**
- Attractive all metal black box packaging provides EMI/RFI shielding.
- **For a unit with Local and Remote Control, See Model 7355, Cat No 307355.**



SPECIFICATIONS:

PORT CONNECTORS: (3) RJ45 female connectors labeled A, B, and COMMON for each of the two channels.

DISPLAY: (4) Front panel LED's display switch position of each channel and power status.

EXCLUSIVE REMOTE CONTROL: (1) RJ45 female connector on rear panel accepts Ethernet 10/100 Base-T connection and either TELNET commands or Graphical User Interface for remote operation.

POWER: UL approved wall mount 100VAC/240VAC, 50Hz/60Hz power module supplies 12 VDC, 500 mA to the unit. Has 2-prong, US, non-polarized plug.

DIMENSIONS: Rackmount configuration 19" W x 1.75" H x 8.05" D. (48.3 x 4.4 x 20.5 cm)

WEIGHT: Approximately 4.2 lbs (2.0 kg)

WIDE RANGE POWER OPTION AVAILABLE: (Cat No 517277) **CE, RoHS, and UL** listed table mount power module, 100VAC/240VAC, 50Hz/60Hz for use in place of standard power module that is included with the unit. Has IEC 60320 C14 inlet. **Ideal for international applications.**

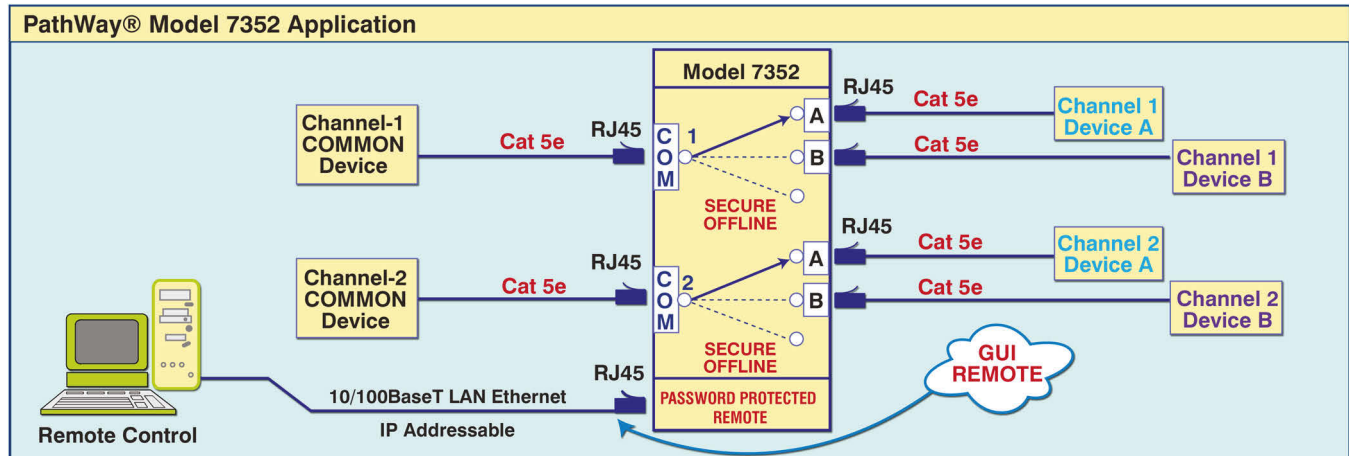

UTILIZING THE USER-FRIENDLY REMOTE GRAPHICAL USER INTERFACE SOFTWARE

To connect to the switch from a workstation or computer having access to the LAN that the Model 7244 LAN port is connected to, simply launch a standard web browser and type in the appropriate IP address. The Java Applet will be automatically uploaded from the switch upon connection. The environment requirement for the GUI is Java 1.7 and above.

10/100BASE-T LAN SETUP

Network Setup

The switch is configured from the factory to use DHCP to automatically get its IP address from a DHCP server on the local area network when connected to the network and powered up. Therefore, a DHCP server is needed on the local area network for the initial configuration. After that, the switch can be configured to use a static IP address. To find the IP address of a switch that it has gotten from the DHCP server, or to reconfigure the IP Address of the switch, use the Lantronix® DeviceInstaller application.

Getting DeviceInstaller

DeviceInstaller requires Microsoft's .NET Framework version 4.0 or higher. If the .NET Framework is not already installed, it must first be installed. The .NET Framework can be downloaded from Microsoft's website, either as a web install, or as a standalone installation. The latest version of DeviceInstaller can be downloaded from Lantronix's website.

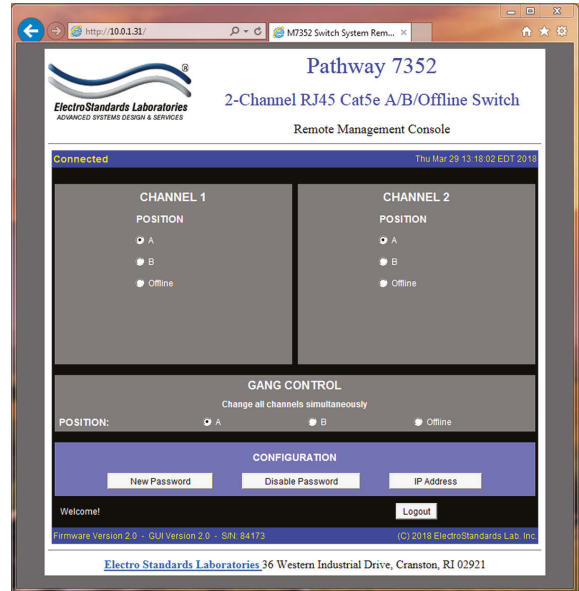

Figure 1: GUI in a Standard Web Browser

SOFTWARE FEATURES

- Access User Interface via standard web browser.
- **Easy to use, simple point and click operation.**
- Remotely access to control or monitor the Model 7352 Switch System.
- Users can change the switch's IP address.
- LAN access gives users across the LAN or over the Internet access to control if user network is configured accordingly.

CHANGING POSITION AND LOCK STATUS

To change the switch position of a channel, click on the radio button "A", "B", or "Offline" as desired for each channel. See Figure 2.

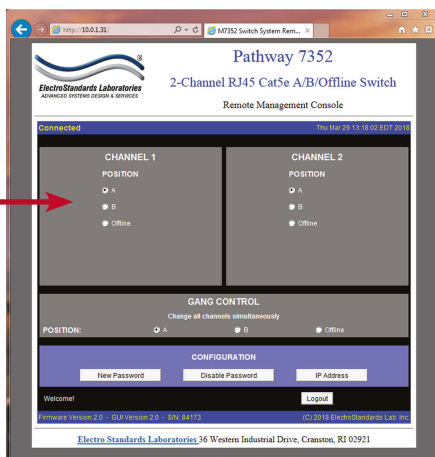

Switch position by selecting "A", "B", or "Offline".

Figure 2: Change the position from the GUI

USING THE GANG CONTROLS

Gang Controls can be used to change the position or state of all channels simultaneously. When all channels are in the same position or state, that position or state will be selected by the Gang Controls. If one of the channels is in a different position or state, that respective Gang Control will not have either option selected. See Figure 3.

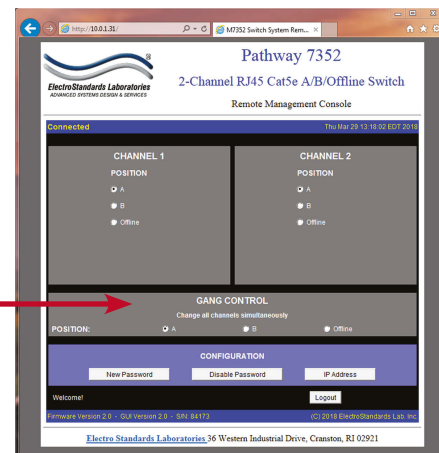

Figure 3: Change both channels simultaneously via Gang Control Operation from the GUI.