

PathWay® Model 7180 Dual Channel BNC 50 Ohm Online/Offline Switch with Contact Closure Remote and Position Feedback

- Ideal for switching BNC connections remotely via contact closure signaling.
- Outstanding for switching Audio.

INTRODUCTION

The PathWay® Model 7180 Dual Channel BNC Online/Offline Switch with Contact Closure Remote allows the user the capability of connecting two separate devices, ports A and B, via an Online or Offline connection, for each channel. The Model 7180 is enclosed in a 1U, full rack size, all metal black chassis designed to provide EMI/RFI shielding and fit in a standard 19" rack.

The switch may be controlled manually via the front panel pushbutton or remotely from a DB9 port located on the rear of the unit. Switch position state may be attained by the front panel LED display or by Remote port monitoring.

FEATURES:

- Simultaneously switch both channels between ONLINE and OFFLINE positions locally via front panel pushbutton, or remotely via a DB9 Remote port.
- Both the Center and Shell of the BNC interface are switched via break-before-make electromechanical relays.
- The switch ports are transparent to all data.
- The unit maintains last set position on power loss and continues to pass data.
- Upon power up, unit switches based on state of Contact Closure.
- Front panel pushbutton control.
- Remote Contact port allows off-site monitoring and switch management.
- Front panel LED's display present position and power status.
- **All BNC ports are impedance matched to support 50 Ohm equipment.**
- Attractive all metal black box packaging provides EMI/RFI shielding.
- Custom length BNC cables available for your switch installation.



SPECIFICATIONS:

PORT CONNECTORS: (2) BNC (F) connectors labeled A and B for each Channel.

FRONT PANEL CONTROL: (1) Manual pushbutton allows local switching.

DISPLAY: (2) Front panel LED's display switch position and power status.

REMOTE CONTROL: (1) DB9 female connector on rear panel accepts Contact Closure Signals for Remote Control Operation.

POWER: UL approved 100VAC/240VAC, 50Hz/60Hz wall mount power module supplies 12 VDC, 500mA to the unit. Has 2-prong, US, non-polarized plug.

DIMENSIONS: Rackmount 19.0" W x 1.75" H x 10.0" D. (48.3 x 4.4 x 25.4 cm), (1U rack height).

WEIGHT: Approximately 5.0 lbs. (2.3 Kg)

WIDE RANGE POWER OPTION AVAILABLE:

(Cat No 517277) **CE, RoHS, and UL** listed table mount power module, 100VAC/240VAC, 50Hz/60Hz for use in place of standard power module that is included with the unit. Has IEC 60320 C14 inlet. **Ideal for international applications.**

Model 7180 Application

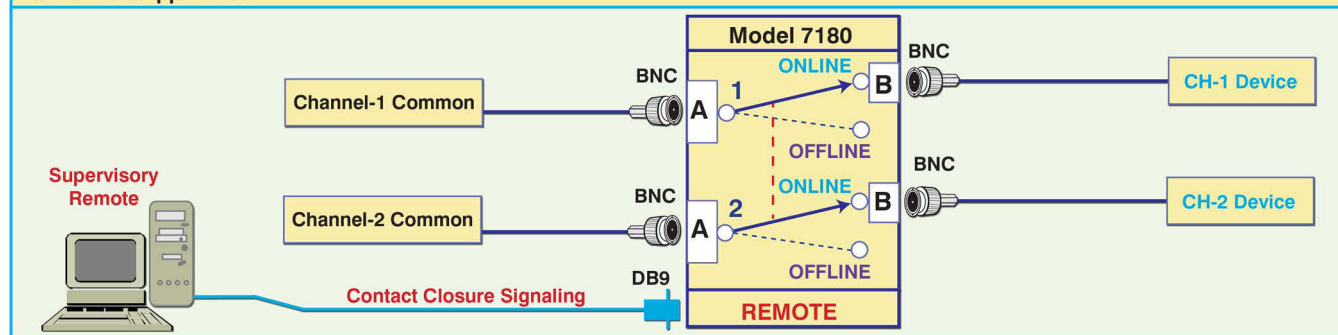

Suggested cables for use with Model 7180 Switch.

Part Number	Description	Unit Price
990136-006	RG58 Coaxial Cable, 50 ohm, 6 ft. (M/M)	32.10
990136-010	RG58 Coaxial, 50 ohm, 10 ft. (M/M)	33.50
890426-006	Thinnet RG58 Coaxial Cable, 50 ohm, 6 ft. (M/M)	33.00
890426-010	Thinnet RG58 Coaxial Cable, 50 ohm, 10 ft. (M/M)	35.00