

QuickSwitch® 6255 Quad Channel LC Duplex A/B Switch with Telnet and GUI

INTRODUCTION

The **QuickSwitch® 6255** Quad Channel LC Duplex A/B Switch with Telnet and GUI allows a device connected to the "COM" port access to the "A" or "B" port for each channel. The switch may be controlled locally by manually operating the front panel pushbutton or remotely from the RJ45 Remote Control port located on the rear of the unit. The RJ45 Remote port provides control through Telnet commands and allows the user to both control and monitor the switch position remotely. The Graphical User Interface is also accessible through the RJ45 Remote port. The front panel LED display indicates the position for each channel and the unit power status.

The **QuickSwitch® 6255** is enclosed in a 2U, full rack size, all metal black chassis designed to fit in a standard 19" rack.



FEATURES:

- Each of four channels allows quick connection to any one of two LC interface devices from one COMMON device.
- **RoHS Compliant**
- The switch ports are transparent to all data.
- Switch maintains position on power loss and continues to pass data.
- Switch powers up in last known position.
- All fiber signals are switched via break-before-make MEMS-based mirror/prism switch technology.
- Independent control via four front panel pushbuttons.
- Control of the switch position from a 10/100-Base-T LAN Ethernet environment. IP Addressable!
- Remote Control Telnet command interface or Graphical User Interface that allows the user to control switch position, lockout front panel operations and obtain switch status.
- Front panel LED's for display the present position for each channel as well as power status.
- **All A, B, and COM ports are LC, Multimode, 62.5/125 micron, and support a wavelength of 850nm.**
- The fiber ports are configured per TIA/EIA-568-B.3, where the TX of the COM port is routed to the RX of the A/B ports and vice versa.

SPECIFICATIONS:

- PORT CONNECTORS:** (3) LC duplex female connectors labeled A, B, and COMMON for each of four channels.
- FRONT PANEL CONTROL:** (4) Manual pushbuttons allow independent channel control. One pushbutton per channel.
- DISPLAY:** (8) Front panel LED's display switch position and power status.
- REMOTE:** (1) RJ45 female connector on rear panel accepts 10/100 Base-T LAN access Ethernet for Remote Control operation.
- POWER:** UL approved 100VAC/240VAC, 50Hz/60Hz wall mount power module supplies 12 VDC, 500mA to the unit. Has 2-prong, US, non-polarized plug.
- DIMENSIONS:** 19.0" W x 3.5" H x 10.75" D. (48.3 x 8.9 x 27.4 cm)
- WEIGHT:** Approximately 4.7 lbs. (2.2 kg)

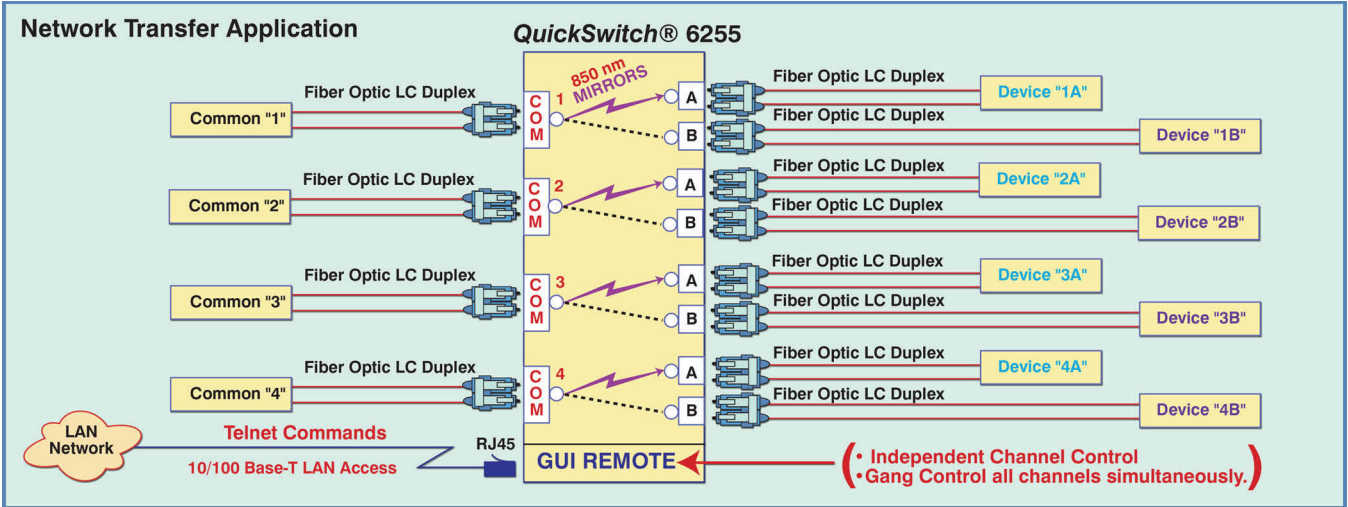

UTILIZING THE REMOTE GRAPHICAL USER INTERFACE SOFTWARE

To connect to the switch from a workstation or computer having access to the LAN that the QuickSwitch® 6255 LAN port is connected to, simply launch a standard web browser and type in the appropriate IP address. The Java Applet will be automatically uploaded from the switch upon connection. The environment requirement for the GUI is Java 1.6 and above.

SOFTWARE FEATURES

★ Graphical User Interface

- **Independent Channel Control:**
 - **Independently** switch positions for Channels 1, 2, 3, and 4.
 - **Independently** lock and unlock individual front panel pushbuttons for Channels 1, 2, 3, and 4.
- **Gang Control:**
 - **Simultaneously** switch positions for all channels via Gang Control.
 - **Simultaneously** lock or unlock all four front panel pushbuttons via Gang Control.
- Access User Interface via standard web browser.
- Easy to use, simple point and click operation.
- Users can change the switch's IP address.
- LAN access gives users across the LAN or over the Internet access to control if user network is configured accordingly.

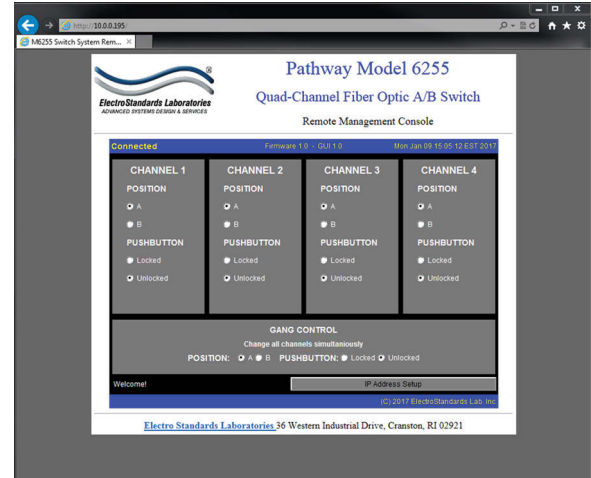
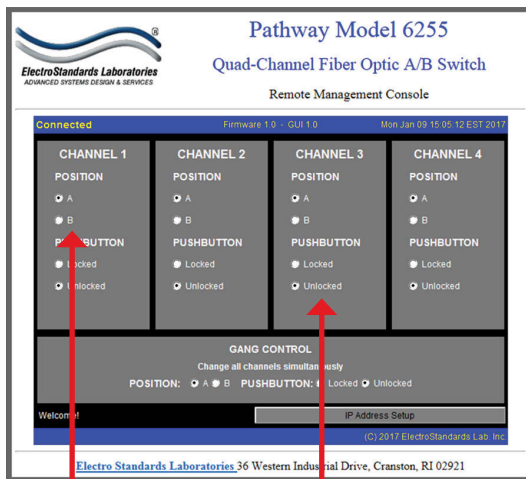

Figure 1: GUI in a Standard Web Browser

CHANGING POSITION AND LOCK STATUS

To change the position for individual channels, click on the radio button for "A" or "B" as desired. Locking and unlocking the front panel pushbutton for each channel can be done by clicking on the "Locked" checkbox.



Switch position by selecting "A" or "B" for each channel.

Lock and unlock the front panel operation for each channel.

Figure 2: Change the position and lockout from the GUI

USING THE GANG CONTROL

Gang controls can be used to change the position or state of all channels simultaneously. When all 4 channels are in the same position or state, that position or state will be selected by the gang controls. If any one of the channels is in a different position or state, that respective gang control will not have either option selected.

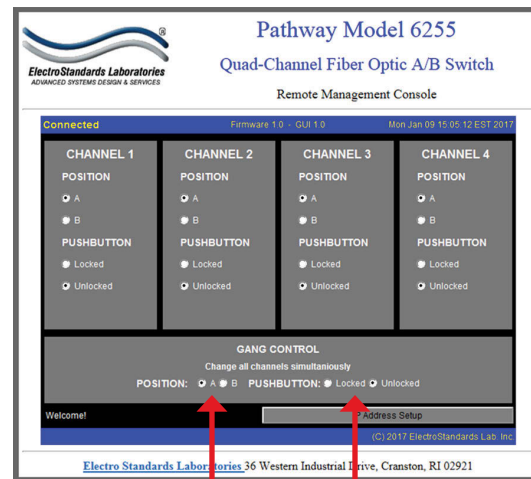

Switch all channels between A and B. If all channels are not in the same position, neither A or B will be selected.

Switch all channels between locked and unlocked. Since all channels are unlocked, unlocked is currently selected.

Figure 3: Gang controls from the GUI.