

QuickSwitch® 5191 8-Way Fiber Optic Switch/Converter w/Remote Control

INTRODUCTION:

QuickSwitch® 5191 allows the user to access any one of eight separate fiber optic network ports, 1-8, from a computer connected to the COMMON 10/100BaseTX port. The fiber optic / twisted pair media conversion is built in! Ports 1-8, are 1300nm 100 Mbps SC multimode fiber optic ports. (ST duplex is available) Customized configurations are available.

QuickSwitch® 5191 control is as simple as pushing the button of the desired network port. LED indicators display the switch position status, as well as the presence of the fiber optic link. **QuickSwitch® 5191 Remote operation** enables the remote user to change the switch position, query the switch position status, and lockout front panel operation.

The **QuickSwitch® 5191** is fully compliant with the 802.3 μ 100Base-FX standard.

FEATURES:

- Access any one of eight separate fiber optic networks from one computer.
- All eight network ports are 1300nm 100 Mbps SC duplex multimode fiber optic ports.
- The COMMON port converts the selected fiber optic network port to the 10/100BaseTX interface.
- Internal circuitry insures isolation between networks / devices.
- Acts as a signal source, no optical signal loss.
- Remotely control the unit from the RS232 serial Remote port.
- Remote is password protected.
- Simple pushbutton switching eliminates plugging and unplugging fiber optic patchcords, minimizing connector wear and increasing system reliability.
- LED display indicates switch position and fiber link presence at a glance.
- Other fiber optic interface network ports are available.
- A 4-Port model is available.

★ **Municipalities, schools, government: This product on GSA Schedule!**



COTS or Customized Switches Available
(Call 401-943-1164)

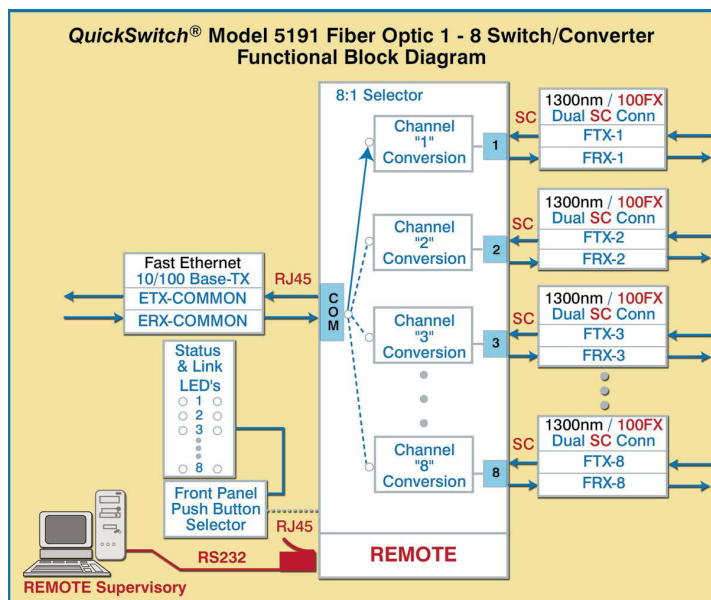

SPECIFICATIONS:

PORT CONNECTORS:

Ports 1- 8 are 100 Base FX fiber optic SC Duplex ports.

(1) COMMON port RJ45 10/100 Base-TX.

FRONT PANEL CONTROLS: (8) Pushbuttons to select network port.

DISPLAY: (8) Status red LED's; (8) Link red LED's.

REMOTE CONTROL PORT: RS232 Serial port, RJ45 connector.

POWER: Wide Range (Cat No 511115) CE, and UL listed table mount power module, 100VAC/240VAC, 50Hz/60Hz is included with the unit. **Ideal for international applications.**

WAVELENGTH: 1300nm,

FIBER SIZE: 62.5/125 Micron.

DIMENSIONS: 11"W x 2.7"H x 8.5"D
(27.9 x 6.9 x 21.6 cm)

WEIGHT: 3 lbs (1.4 kg)