

# Model 4504 Ruggedized DB25 A/B Switch

• **Ruggedized to withstand Environmental Challenges**

### INTRODUCTION

Model 4504 was designed to withstand an environment subject to vibrations. Model 4504 is ideal for mobile/motion applications, or any other harsh environment application.

Model 4504 allows data to pass through 24 pins of the DB25 connector interface and switches the 24 pins simultaneously. Model 4504 switch is available with mounting brackets to secure it to a panel.

### FEATURES:

- Switches pins 2 to 25 of connector interface, simultaneously. Chassis Ground on pin 1 bussed thru.
- Ruggedized to withstand vibrations encountered in mobile/motion applications.
- Switch Configuration has passed rigorous seismic testing.
- Ideal for mobile/motion applications.
- Rugged all-aluminum enclosure provides EMI/RFI resistance in noisy environments.
- Optional "mounting ears" allow firm attachment.
- Manually operated. No power required.
- Lifetime guarantee against manufacturing defects!

★ **Municipalities, schools, government: This product is on GSA Schedule!**



### SPECIFICATIONS:

**PORT CONNECTORS:** (2) DB25 female connectors labeled "FAX", and "COMM SERVER", and (1) DB25 male connector labeled COMMON.

**FRONT PANEL CONTROLS:** (1) Two position manual rotary switch allows local switching. The switch positions are labeled "FAX" and "COM SERVER".

**DIMENSIONS:** Desktop 4.25" W x 3.5" H x 6.0" D. (10.8 x 8.9 x 15.2 cm)

**WEIGHT:** Approximately 2.0 lbs. (1.0 Kg)

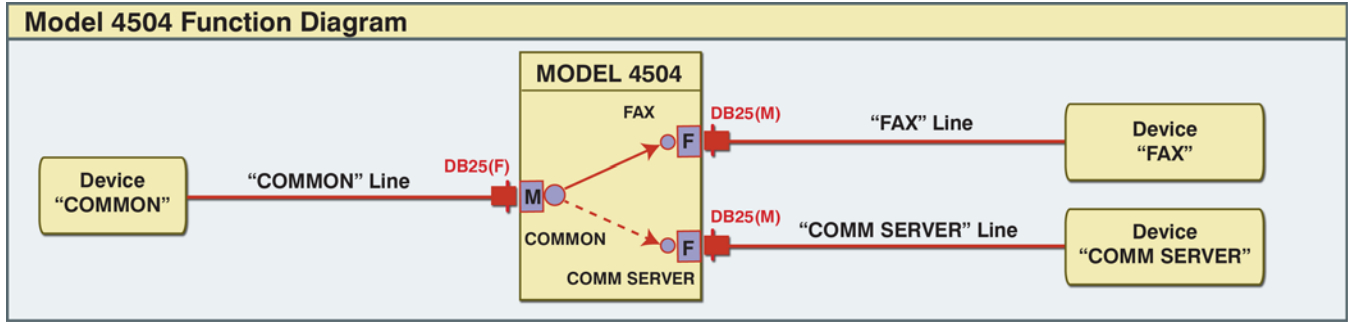

**Custom length data network cables 25-conductor, DB25/DB25, Unshielded, PVC.**

Part Number	Connectors	Length Specify XXX-FT	Price (USD)
990104-XXX	F/F	XXX-FT	\$19.00 + 0.55 / FT
990105-XXX	M/F	XXX-FT	\$19.00 + 0.55 / FT
990106-XXX	M/M	XXX-FT	\$19.00 + 0.55 / FT