

QuickSwitch® 4289 4-Way Fiber Optic Switch/Converter

QuickSwitch® 4289 Features

- Access any one of four separate fiber optic networks from one computer.
- Simple pushbutton switching eliminates the need to plug/unplug fiber optic patchcords thus minimizing connector wear, and increasing system reliability.
- All four network ports are 1300nm **100 Mbps ST** multimode fiber optic ports, ST duplex shown, SC duplex available.
- Internal circuitry insures isolation between networks/devices.
- Acts as a signal source, no optical signal loss.
- LED display indicates switch position and fiber link presence at a glance.
- Other fiber optic interface network ports are available.



COTS or Customized Switches Available
(Call 401-943-1164)

QuickSwitch® 4289 Operation

QuickSwitch® 4289 allows user to access any one of four separate fiber optic network ports, 1, 2, 3, or 4, from a computer connected to the COMMON 100 Base-TX port. All ports are 1300nm 100 Mbps ST duplex multimode fiber optic ports. Customized configurations are available.

QuickSwitch® is controlled from the front panel pushbutton switches. Front panel control is as simple as depressing the button of the desired network port. LED indicators display the switch position status, as well as the presence of the fiber optic link.

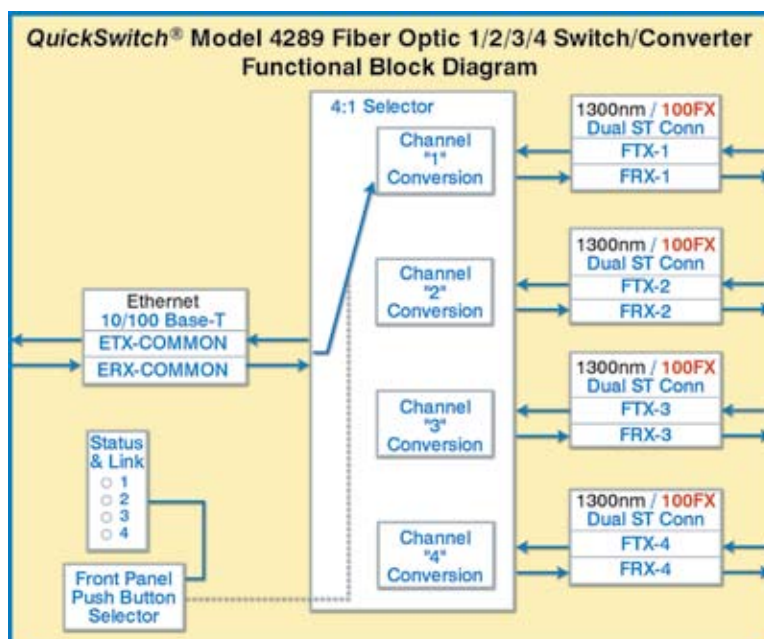

SPECIFICATIONS:

CONNECTORS - Ports 1, 2, 3, 4 are 100 Base FX fiber optic ST duplex ports; COMMON port is 10/100 Base-TX, RJ45.

FIBER OPTIC PORT INTERFACE - Ports 1, 2, 3, 4 are 1300nm, speed 100MBPS, full duplex.

CONTROLS - (4) Pushbuttons to select network port.

DISPLAY - (4) Status red LED's; (4) Link red LED's.

POWER - 115VAC / 60HZ wall mount supply.

DIMENSIONS - 11"W x 2.7"H x 8.5"D, wt. 3 lbs.